



LM7596 Simple Switcher Power Converter 150kHz 3A Step-Down Voltage Regulator

DESCRIPTION

The LM7596 series of regulators are monolithic integrated circuits that provide all the active functions for a step-down switching regulator, capable of driving a 3A load with excellent line and load regulation. These devices are available in fixed output voltages of 3.3V, 5V, 12V and an adjustable output version.

Requiring a minimum number of external components, these regulators are simple to use.

The LM7596 series operates at a switching frequency of 150kHz. Available in standard 5-lead TO-220 package.

Other features include a guaranteed $\pm 3\%$ tolerance on output voltage under specified input voltage and output load conditions, and $\pm 15\%$ on the oscillator frequency. External shutdown is included, featuring typically 100 μ A standby current. Self protection features include a two stage frequency reducing current limit for output switch and an over temperature shutdown for complete protection under fault conditions. The over temperature shutdown level is about 145°C with 5°C hysteresis.

FEATURES

- 3.3V, 5V, 12V, and adjustable output versions
- Adjustable version output voltage range, 1.2V to 37V $\pm 3\%$ max over line and load conditions
- Available in TO-220
- Guaranteed 3A output load current
- Input voltage range up to 40V
- Requires only 4 external components
- Excellent line and load regulation specifications
- 150 kHz fixed frequency internal oscillator
- TTL shutdown capability
- Low power standby mode, I_Q typically 100 μ A
- High efficiency
- Thermal shutdown and current limit protection

APPLICATIONS

- Simple high-efficiency step-down (buck) regulator
- On-card switching regulators
- Positive to negative converter

TYPICAL APPLICATION (Fixed Output Voltage Versions)

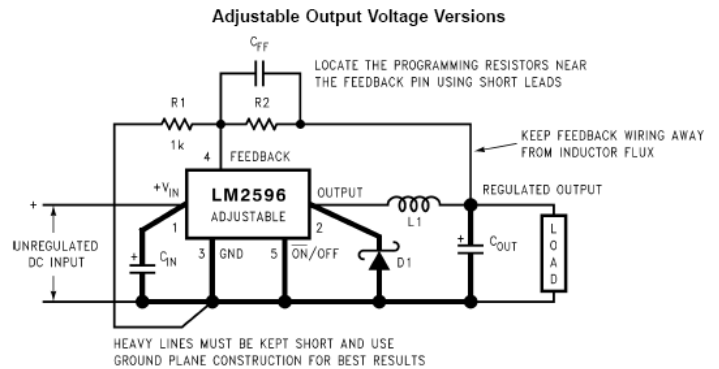
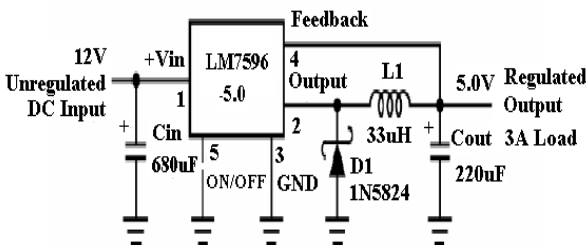

CONNECTION DIAGRAMS AND ORDERING INFORMATION

Bent and Staggered Leads, Through Hole Package 5-Lead TO-220

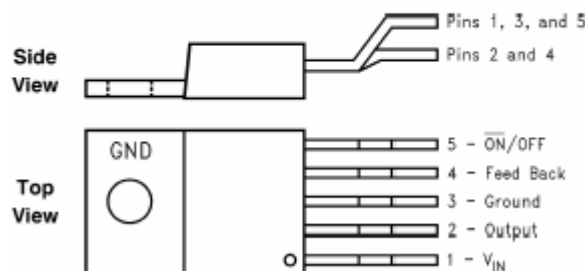



LM7596 Simple Switcher Power Converter 150kHz 3A Step-Down Voltage Regulator

Absolute Maximum Ratings

Maximum Supply Voltage	45V
ON /OFF Pin Input Voltage	$-0.3 \leq V \leq +25V$
Feedback Pin Voltage	$-0.3 \leq V \leq +25V$
Output Voltage to Ground	-1V
Storage Temperature Range	-65°C to $+150^{\circ}\text{C}$
Power Dissipation	Internally limited
Maximum Junction Temperature	$+150^{\circ}\text{C}$

Operating Conditions

Temperature Range	$-40^{\circ}\text{C} \leq T_J \leq +125^{\circ}\text{C}$
Supply Voltage	4.5V to 40V

ELECTRICAL CHARACTERISTICS

Unless otherwise specified, $T_J = 25^{\circ}\text{C}$. $V_{IN} = 12V$ for the 3.3V, 5V and Adjustable version and $V_{IN} = 24V$ for the 12V version. $I_{LOAD} = 500\text{mA}$.

Characteristic	Symbol	Test Condition	Min	Typ	Max	Unit
Output Voltage	V_{OUT}	LM7596-3.0 $4.75V \leq V_{IN} \leq 40V$, $0.2A \leq I_{LOAD} \leq 3A$	3.20	3.30	3.40	V
		LM7596-5.0 $7V \leq V_{IN} \leq 40V$, $0.2A \leq I_{LOAD} \leq 3A$	4.85	5.0	5.15	
		LM7596-12 $15V \leq V_{IN} \leq 40V$, $0.2A \leq I_{LOAD} \leq 3A$	11.64	12.0	12.36	
Efficiency	η	LM7596-3.0 $I_{LOAD} = 3A$		73		%
		LM7596-5.0 $I_{LOAD} = 3A$		80		
		LM7596-12 $V_{IN} = 24V, I_{LOAD} = 3A$		90		
		LM7596-Adj $V_{IN} = 12V, V_{OUT} = 3V$, $I_{LOAD} = 3A$		73		
Feedback Voltage	V_{FB}	LM7596-Adj $4.5V \leq V_{IN} \leq 40V$, $0.2A \leq I_{LOAD} \leq 3A$, V_{OUT} programmed for 3V	1.210	1.230	1.250	V
Feedback Bias Current	I_b	LM7596-Adj $V_{FB} = 1.3V$		15	50	nA
Oscillator Frequency	f_o		127	150	173	kHz
Saturation Voltage	V_{SAT}	$I_{OUT} = 3A$ (Note 1,2)		1.16	1.4	V
Max Duty Cycle (ON)	DC	(Note 2)		100		%
Min Duty Cycle (OFF)		(Note 3)		0		
Current Limit	I_{CL}	Peak Current (Note 1,2)	3.4	4.5	6.0	A
Output Leaked Current	I_L	Output = 0V (Note 1,3)			50	μA
		Output = -1V, $V_{IN} = 40V$		2	30	mA
Quiescent Current	I_Q	(Note 3)		5	10	mA
Standby Quiescent Current	I_{STBY}	ON/OFF pin = 5V (OFF), $V_{IN} = 40V$		100	200	μA
ON/OFF Pin Logic Input Threshold Voltage	V_{IH} V_{IL}	Low (Regulator ON)			0.6	V
		High (Regulator OFF)	2.0			
ON/OFF Pin Input Current	I_H	$V_{LOGIC} = 2.5V$ (Regulator OFF)		5	15	μA
	I_L	$V_{LOGIC} = 0.5V$ (Regulator ON)		0.02	5	

Note 1: No elements connected to output pin.

Note 2: Feedback pin removed from output and connected to 0V to force the output transistor switch ON.

Note 3: Feedback pin removed from output and connected to 12V for the 3.3V, 5V, and the A version, and 15V for the 12V version. To force the output transistor switch OFF.



LM7596 Simple Switcher Power Converter 150kHz 3A Step-Down Voltage Regulator

PHYSICAL CHARACTERISTICS

- Wafer Diameter.....100 ± 0.5 mm
- Wafer Thickness.....350 ± 20 μm
- Scribe Width..... 100 μm
- Passivation.....PSG
- Metallization bottom..... Ti-Ni-Ag
 - Ti-Ni – 0.5-0.7μm
 - Ag – 0.6-0.1μm

PAD LOCATION COORDINATES

Pad No	Pad Name	X (μm)	Y (μm)
1	V _{IN}	463	1252
1A	V _{IN}	225	-95
2	OUTPUT	-445	547
2A	OUTPUT	-245	615
3	GROUND	-875	-120
4	FEEDBACK	-875	-1355
5	ON/OFF	875	-1355

Note:

- ◆ The chip substrate is electrically connected to GND (Pad 3)
- ◆ Pads 1 and 1A are internally connected
- ◆ Pads 2 and 2A are internally connected

LM7596 PAD LAYOUT

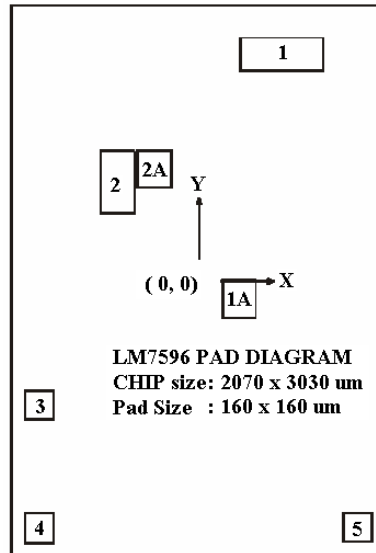

BONDING DIAGRAM

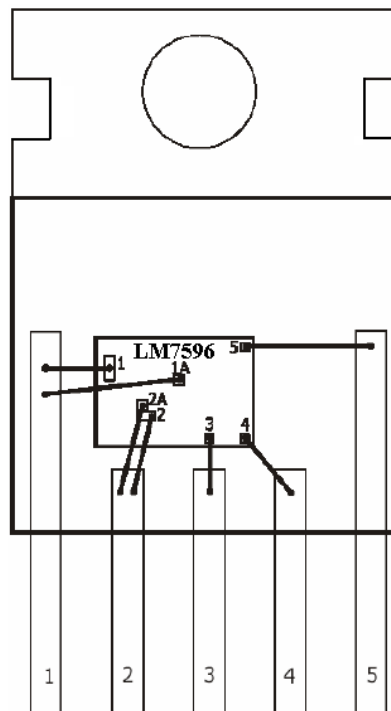

Note:

- Wire diameter > 60 micron
- PAD 1 and PAD 1A (V_{IN}) are connected to the Pin1.
- PAD 2 and PAD 2A (OUTPUT) are connected to the Pin 2.
- PAD 3 (GROUND) is connected to the Pin 3.
- PAD 4 (FEEDBACK) is connected to the Pin 4.
- PAD 5 (ON/OFF) is connected to the Pin 5.